

ROHM Solution Simulator

4.5 V to 28 V Input, 1 A Integrated MOSFET Single Synchronous Buck DC/DC Converter BD9E105FP4-Z / Frequency Response

This circuit simulates the frequency response of BD9E105FP4-Z. You can observe the loop gain and measure phase margin. You can customize the simulation conditions by changing the parameters of components highlighted in blue. You can simulate the circuit in the published application note: Measurement Method for Phase Margin with FRA. [\[JP\]](#) [\[EN\]](#) [\[CN\]](#)

General Cautions

- Caution 1:** The values from the simulation results are not guaranteed. Use these results as a guide for your design.
- Caution 2:** These model characteristics are specifically at $T_a = 25\text{ }^\circ\text{C}$. Thus, the simulation result with temperature variances may significantly differ from the result with the one done at actual application board (actual measurement).
- Caution 3:** Please refer to the datasheet for details of the technical information.
- Caution 4:** The characteristics may change depending on the actual board design and ROHM strongly recommend to double check those characteristics with actual board where the chips will be mounted on.

1 Simulation Schematic

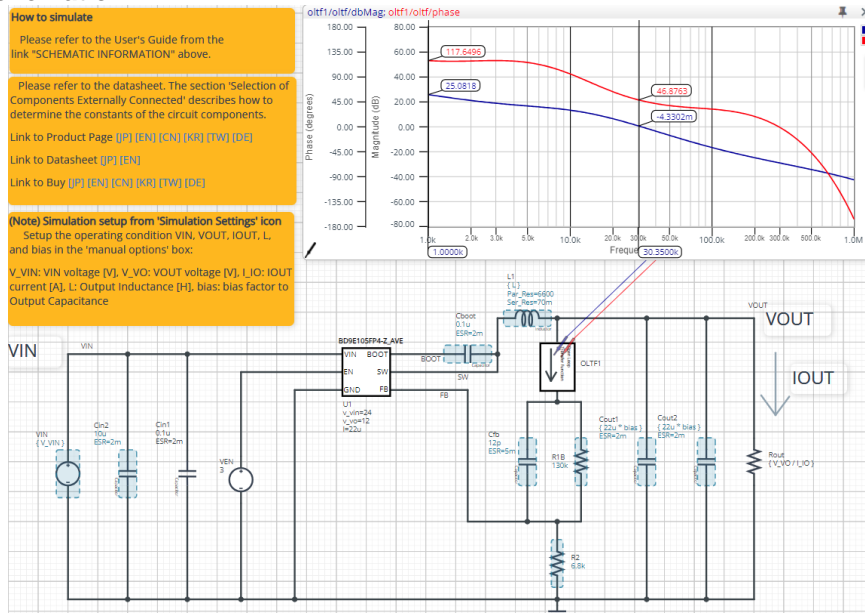

Figure 1. Simulation Circuit

2 How to simulate

The simulation settings, such as frequency range or convergence options, are configurable from the 'Simulation Settings' shown in Figure 2, and Table 1 shows the default setup of the simulation.

In case of simulation convergence issue, you can change advanced options to solve.

The parameters V_VIN , V_VO , I_IO , L and bias are defined in the 'Manual Options'.

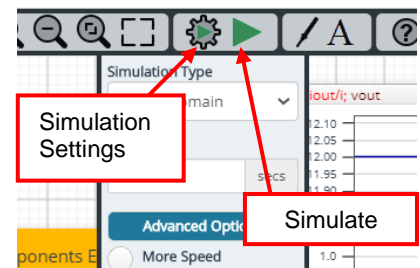

Figure 2. Simulation Settings and execution

Table 1. Simulation settings default setup

Parameters	Default	Note
Simulation Type	Frequency-Domain	(Do not change Simulation Type)
Start Frequency	1k Hz	Simulate the frequency response for the frequency range from 1 kHz to 1 MHz.
End Frequency	1Meg Hz	
Advanced options	Balanced Convergence Assist	
Manual Options	“.param V_VIN=24 V_VO=12 I_IO=1 L=22u bias=0.2”	See “Simulation Condition” for details

3 Simulation Conditions

3.1 How to define V_{IN} , V_{OUT} , I_{OUT} , L, and bias factor

These parameters are used to setup the simulation conditions and BD9E105FP4-Z_AVE model parameters, therefore these are defined in the Manual Options as the common variables.

Table 2 shows the default value of V_{IN} , V_{OUT} , I_{OUT} , L, and bias. Those values are defined and can be set in the 'Manual Options' text box from Simulation Settings as shown in Figure 3.

The input voltage of V_{IN} , output inductance of L1, and the load resistance of R_{out} are automatically set according to those parameters. Note that feedback resistors are not automatically set by V_{VO} . Set R1 and R2 manually.

Table 2. Simulation Conditions

Parameters	Variable Name	Default Value	Units	Descriptions
V_{IN}	V_VIN	24	V	Input Voltage
V_{OUT}	V_VO	12	V	Output Voltage
I_{OUT}	I_IO	1	A	Output Current
L	L	22u	H	Output Inductor
bias factor	bias	0.2	-	Bias factor to Output Capacitance

(Note 1) Set it to the guaranteed operating range of the DC/DC Converter.

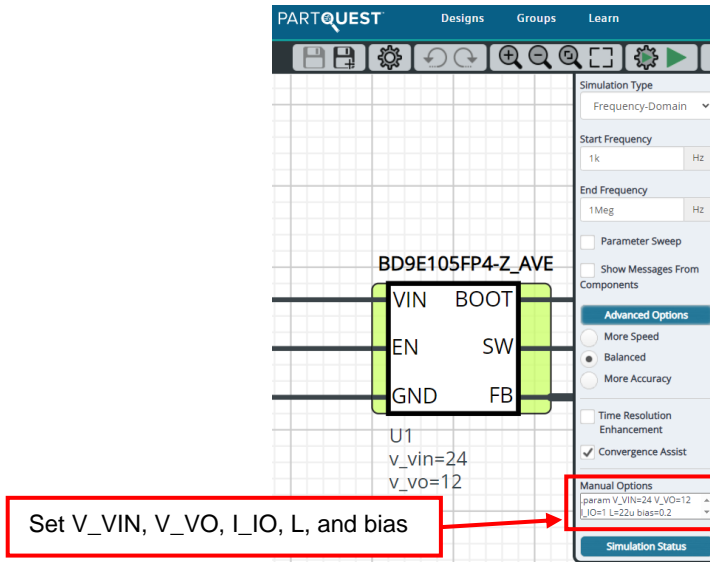

Figure 3. Definition of V_{IN} , V_{OUT} , I_{OUT} , L, and bias factor

3.2 Resistive Load Rout

R_{out} is the resistive load and its resistance is determined from V_{OUT} and I_{OUT} . The resistance value is defined using the equation below.

Table 3. Resistive load

Instance Name	Default Value	Unit
R_{out}	$\{ V_{VO} / I_{IO} \}$	Ω

4 BD9E105FP4-Z_AVE model

The simulation model in this circuit is designed for frequency response, and the functions not related to frequency response are not implemented.

Table 4. BD9E105FP4-Z_AVE model pins used for frequency response

Pin Name	Description
VIN	Power supply input.
EN	Enable input.
BOOT	Pin for bootstrap.
SW	Switching node.
FB	Output voltage feedback pin. Inverting input node of the error amplifier.
GND	Ground.

4.1 BD9E105FP4-Z_AVE Model Parameters

BD9E105FP4-Z_AVE model has its parameters shown in Table 5. All the parameters are pre-defined and fixed in the simulation. V_VIN is substituted to V_VIN as shown in Table 5.

Table 5. Parameter List

Parameters	Default Values	Description
V_VIN	V_VIN	VIN voltage
V_VO	V_VO	VOOUT voltage
L	L	Output inductance

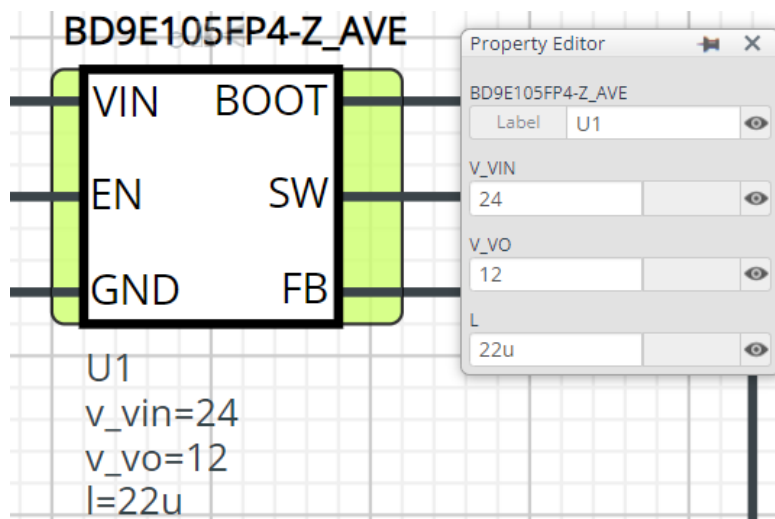

Figure 4. Property Editor of BD9E105FP4-Z_AVE model

5 Peripheral Components

To set parameters of components, open 'property' by double click or right click on a component. You can input a value to a property text box if available. Please refer to the hands-on manual for more details.

5.1 Bill of Material

Table 6 shows the list of components used in the simulation schematic. Each of the capacitor and inductor has the parameters of equivalent circuit shown below. The default value of equivalent components are set to zero except for the parallel resistance of L and series resistance of capacitors. You can modify the values of each component.

Table 6. List of components used in the simulation circuit

Type	Instance Name	Default Value	Units
Capacitor	Cin1	0.1	μF
	Cin2	10	μF
	Cboot	0.1	μF
	Cout1	22	μF
	Cout2	22	μF
	Cfb	12	pF
Inductor	L1	22	μH
Resistor	R1	130	kΩ
	R2	6.8	kΩ

5.2 Capacitor Equivalent Circuits

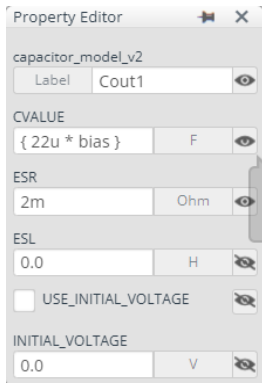

(a) Property editor
Figure 5. Capacitor

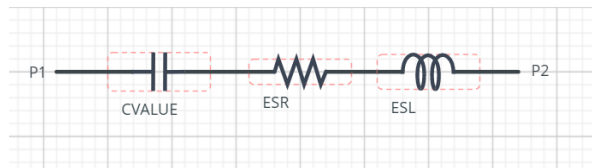

(b) Equivalent circuit
property editor and equivalent circuit

The default value of ESR is 2 mΩ.

5.3 Inductor Equivalent Circuits

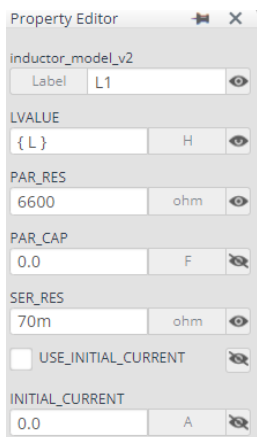

(a) Property editor
Figure 6. Inductor

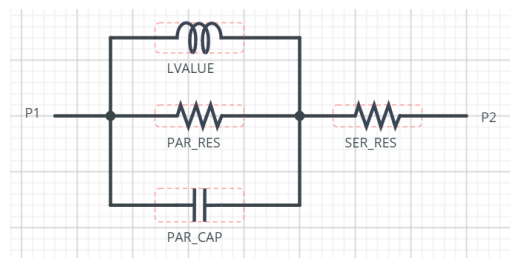

(b) Equivalent circuit
property editor and equivalent circuit

The default value of PAR_RES is 6.6 kΩ.

(Note 2) These parameters can take any positive value or zero in simulation but it does not guarantee the operation of the IC in any condition. Refer to the datasheet to determine adequate value of parameters.

6 Open Loop Transfer Function (OLTF) Monitor

OLTF1 is the insert model to measure AC open loop transfer function and is inserted to acquire the gain and phase output. To monitor the gain and phase from OLTF1, select probe items 'dbMag' for gain and 'phase' for phase plot, respectively from 'property' of OLTF1.

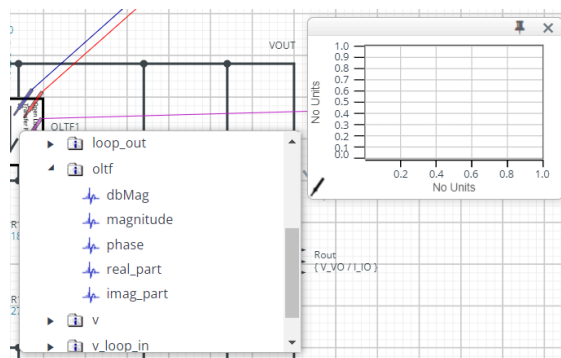

Figure 7. Probe Items of OLTF1

7 Link to the product information and tools

7.1 DC/DC Converter

BD9E105FP4-Z : Integrated MOSFET Single Synchronous Buck DC/DC Converter. [\[JP\]](#) [\[EN\]](#) [\[CN\]](#) [\[KR\]](#) [\[TW\]](#) [\[DE\]](#)

7.2 General Purpose Chip Resistors

MCR01MZPF : Thick Film Chip Resistors. [\[JP\]](#) [\[EN\]](#) [\[CN\]](#) [\[KR\]](#) [\[TW\]](#) [\[DE\]](#)

Technical Articles and Tools can be found in the Design Resources on the product web page.

Notice

- 1) The information contained in this document is intended to introduce ROHM Group (hereafter referred to as ROHM) products. When using ROHM products, please verify the latest specifications or datasheets before use.
- 2) ROHM products are designed and manufactured for use in general electronic equipment and applications (such as Audio Visual equipment, Office Automation equipment, telecommunication equipment, home appliances, amusement devices, etc.) or specified in the datasheets. Therefore, please contact the ROHM sales representative before using ROHM products in equipment or devices requiring extremely high reliability and whose failure or malfunction may cause danger or injury to human life or body or other serious damage (such as medical equipment, transportation, traffic, aircraft, spacecraft, nuclear power controllers, fuel control, automotive equipment including car accessories, etc. hereafter referred to as Specific Applications). Unless otherwise agreed in writing by ROHM in advance, ROHM shall not be in any way responsible or liable for any damages, expenses, or losses incurred by you or third parties arising from the use of ROHM Products for Specific Applications.
- 3) Electronic components, including semiconductors, can fail or malfunction at a certain rate. Please be sure to implement, at your own responsibilities, adequate safety measures including but not limited to fail-safe design against physical injury, and damage to any property, which a failure or malfunction of products may cause.
- 4) The information contained in this document, including application circuit examples and their constants, is intended to explain the standard operation and usage of ROHM products, and is not intended to guarantee, either explicitly or implicitly, the operation of the product in the actual equipment it will be used. As a result, you are solely responsible for it, and you must exercise your own independent verification and judgment in the use of such information contained in this document. ROHM shall not be in any way responsible or liable for any damages, expenses, or losses incurred by you or third parties arising from the use of such information.
- 5) When exporting ROHM products or technologies described in this document to other countries, you must abide by the procedures and provisions stipulated in all applicable export laws and regulations, such as the Foreign Exchange and Foreign Trade Act and the US Export Administration Regulations, and follow the necessary procedures in accordance with these provisions.
- 6) The technical information and data described in this document, including typical application circuits, are examples only and are not intended to guarantee to be free from infringement of third parties intellectual property or other rights. ROHM does not grant any license, express or implied, to implement, use, or exploit any intellectual property or other rights owned or controlled by ROHM or any third parties with respect to the information contained herein.
- 7) No part of this document may be reprinted or reproduced in any form by any means without the prior written consent of ROHM.
- 8) All information contained in this document is current as of the date of publication and subject to change without notice. Before purchasing or using ROHM products, please confirm the latest information with the ROHM sales representative.
- 9) ROHM does not warrant that the information contained herein is error-free. ROHM shall not be in any way responsible or liable for any damages, expenses, or losses incurred by you or third parties resulting from errors contained in this document.



Thank you for your accessing to ROHM product informations.
More detail product informations and catalogs are available, please contact us.

ROHM Customer Support System

<https://www.rohm.com/contactus>